

THIS DRAWING IS UNPUBLISHED. RELEASED FOR PUBLICATION
 © COPYRIGHT 19 BY AMP INCORPORATED. ALL INTERNATIONAL RIGHTS RESERVED.

LOC		DIST		P		F		REVISIONS		DATE	APPD
ZONE	LTR	DESCRIPTION									
AF	50							5	REV PER 0G3A-0403-01	28 Jun 01	JR/DD

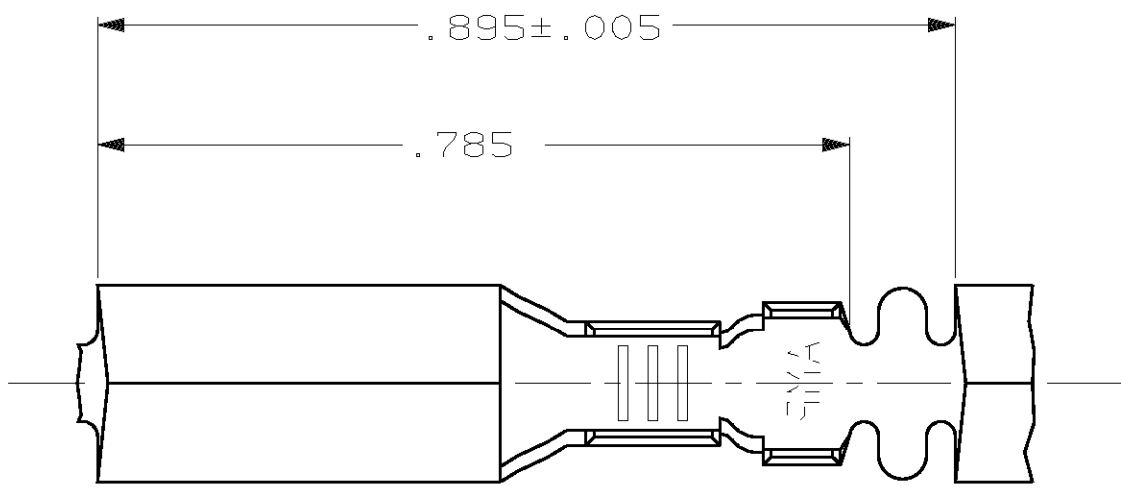

- 1 CONTINUOUS STRIP ON REELS
- 2 PRE-PLATE .000100 MIN TIN OVER .000050 MIN NICKEL, POST PLATE .000080 MIN TIN PER MIL-T-10727
- 3 .000080 MIN TIN PL PER MIL-T-10727.
- 4 WITH INTERLEAVING PAPER.
- 5 PRELIMINARY - NOT FOR PRODUCTION.

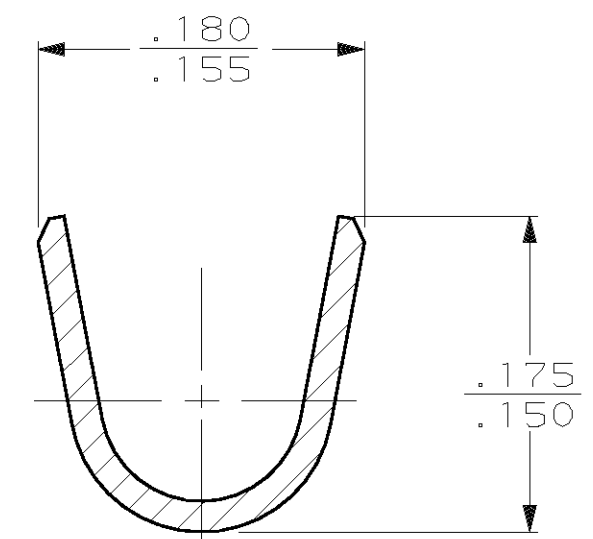
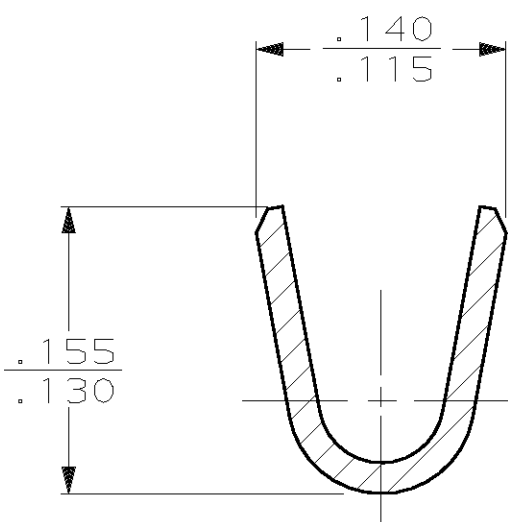
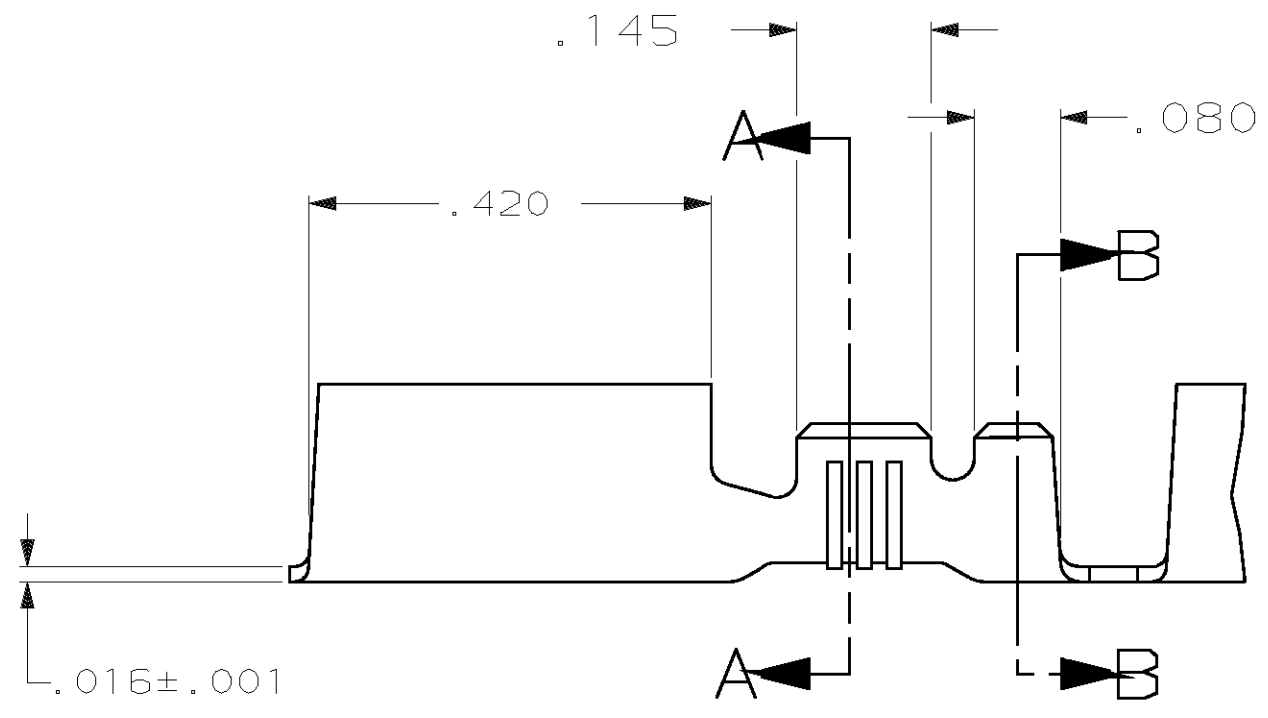
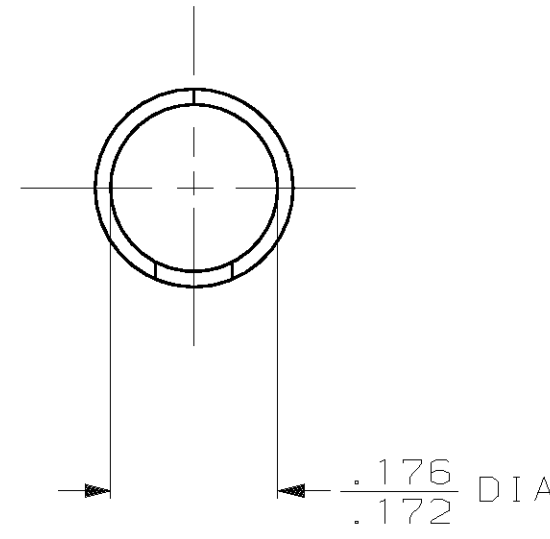

SECTION A-A
SCALE 10:1

SECTION B-B
SCALE 10:1

MATERIAL	FINISH	INSULATION DIA	WIRE RANGE	PART NO
4M BRASS	3	.090-.125	18-14	4 60799-6
4M BRASS	3			5 60799-5
PHOS BRONZE	2			60799-4
4M BRASS				60799-2

TYPE	WIDTH	STRIP LENGTH ±.015	TYPE	WIDTH	±.002 HEIGHT	WIRE
F OR O	.140	.210	F	.100	.077	14
					.067	16
					.061	18
INSUL BARREL CRIMP			WIRE BARREL CRIMP			

DO NOT SCALE PRINT. UNLESS SPECIFIED DIMENSIONS IN INCHES TOLERANCES ON:

DR 12/13/88 P FORTNEY	AMP INCORPORATED Harrisburg, Pa. 17105
CHK 6/14/89 MS FEHER	
APPD 6/14/89 G YETTER	NAME RECEPTACLE, SHUR PLUG, .180 DIA
APPD 6/14/89 R KUZO	
PRODUCT SPEC	SIZE C FSCM NO 00779 DRAWING NO 60799
APPLICATION SPEC	SCALE 5:1 SHEET 1 OF 1
WEIGHT -	